

Credo Ti:Sa FCUs

High Repetition Rate Credo Ti:Sa Frequency Conversion Units

The compact solid-state high repetition rate Credo Titanium:Sapphire-Laser is designed for applications where a wide tuning range and high pulse intensity with narrow linewidth is needed. Typical applications are atmospheric research, combustion research, material science, semiconductor technology, and environmental analysis. Most wavelengths for these measurements are in the UV.

To reach this wavelength range four non-linear conversion units (FCUs) are available: doubling (SHG), tripling (THG), fourth harmonic (4HG) and the fifth harmonic (5HG).

Output power in the wavelength range from 470 nm down to 192 nm can be produced with good conversions because of the good beam profile of the fundamental Ti:Sa laser.

Power Output SHG

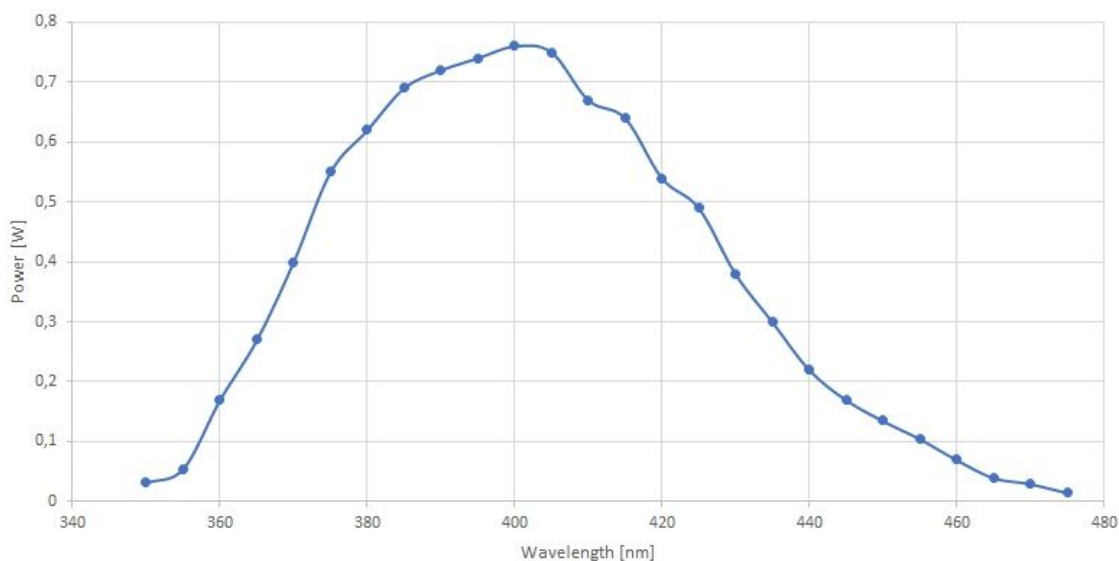

General Characteristics SHG

Tuning Range	350 .. 475 nm
Output Power	> 0.7 W at peak (fundamental: 2.5 W, 1kHz)
Linewidth	< 0.3 cm ⁻¹

Power Output THG, 4HG, 5HG

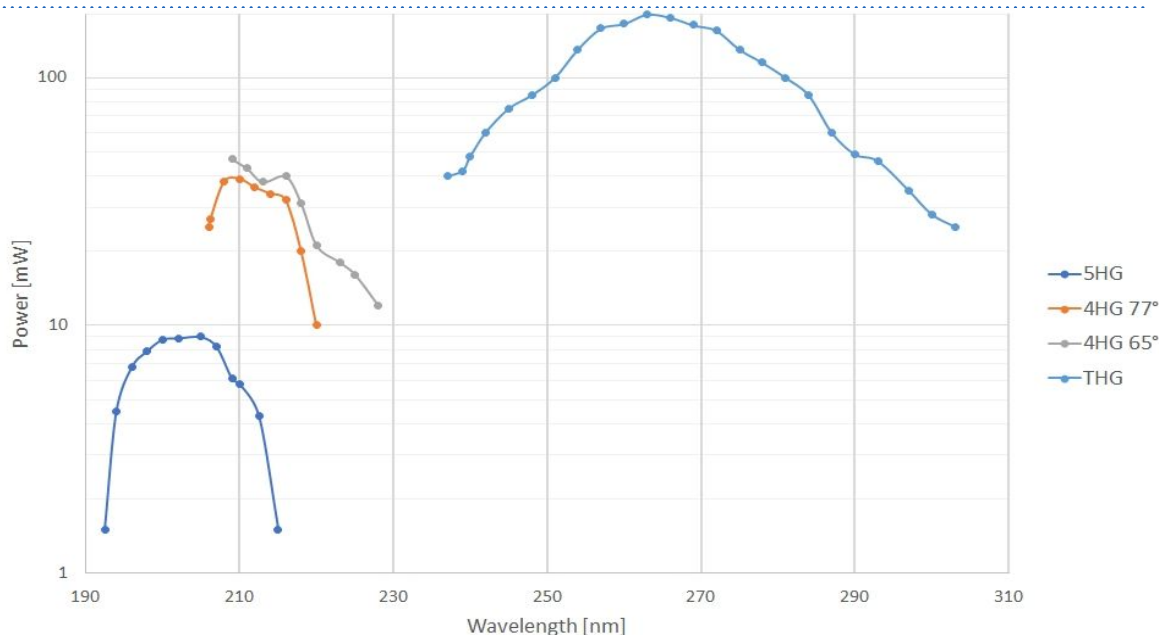

Credo Ti:Sa THU + 4HG

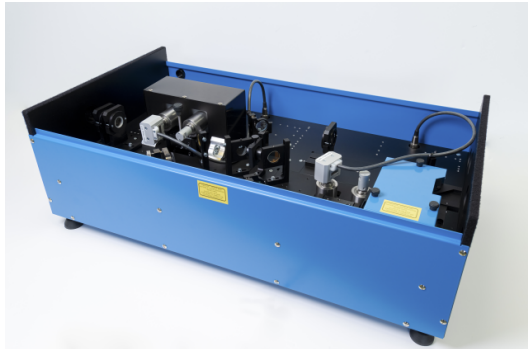

5HG

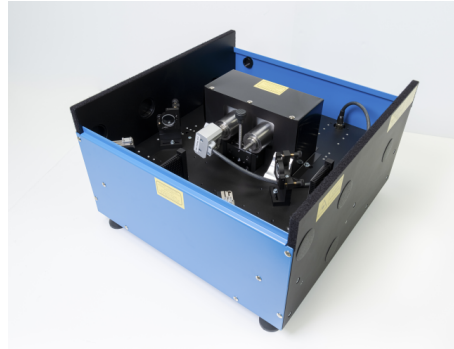

General Characteristics THG

Tuning Range	238 .. 305 nm
Output Power	> 150 mW at peak (fundamental peak: 2.5 W, 1kHz)
Linewidth	< 0.35 cm ⁻¹

General Characteristics 4HG

Tuning Range	206 .. 225 nm
Output Power	> 35 mW at peak (fundamental peak: 2.5 W, 1kHz)
Linewidth	< 0.35 cm ⁻¹

General Characteristics 5HG

Tuning Range	192 .. 215 nm
Output Power	> 8 mW at peak (fundamental peak: 2.5 W, 1kHz)
Linewidth	< 0.4 cm ⁻¹

Optical Layout for 5HG

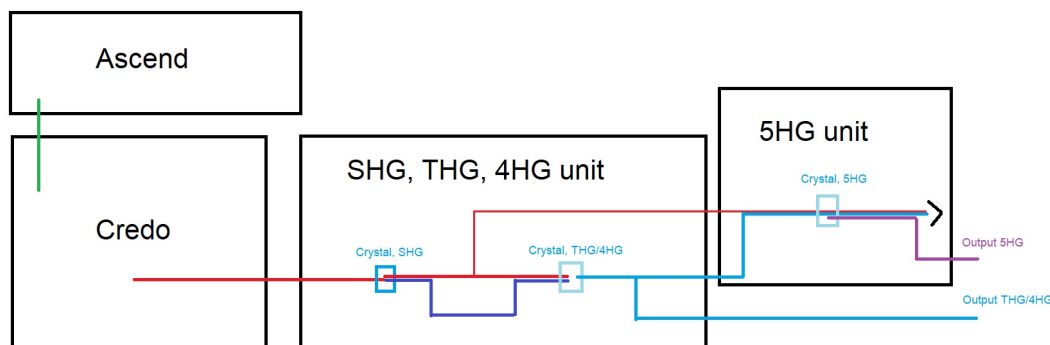

Requirements

Laser	Ascend 40/60 + Credo Ti:Sa
Ambient Conditions	constant temperature in the 20 .. 25°C range
Laboratory	dust-free air (flow box recommended)
Voltage	110 .. 230 V, single phase, 50 / 60 Hz
Computer Control	Windows 7 - 8 / Windows 10 - 11 (32 & 64 bit), USB Port

Specifications are subject to change without notice

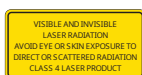

Heinrich-Hertz-Straße 11
D-41516 Grevenbroich

phone +49 21 82.82 98 18-0
fax +49 21 82.82 98 18-40