

# MixTrain 5/10

## Frequency Mixing in Periodically Poled Crystals

The MixTrain is using quasi-phase matching in periodically poled crystals for difference frequency mixing of two cw-lasers. Typically, one of the lasers will be a tunable Titanium-Sapphire laser like the Matisse while the other laser is a powerful fixed wavelength fiber laser operating at 532 nm and 1064 nm.

The system uses a motor controlled translation stage for changing the period of the crystal and a temperature stabilized oven capable of heating up to 180 °C.

All optics for beam shaping, polarization control, beam combination, and beam separation are included. An optical diode isolates the fiber laser input from back reflections from the setup.

The doubled fiber laser at 532 nm can be ordered with a second beam output for the residual 1064 nm. The MixTrain Optics can be used for 532 nm and 1064 nm. A shift mirror construction in the pump path allows for easy change between the two input wavelengths for the MixTrain with minimal readjustment.

## Tuning Range

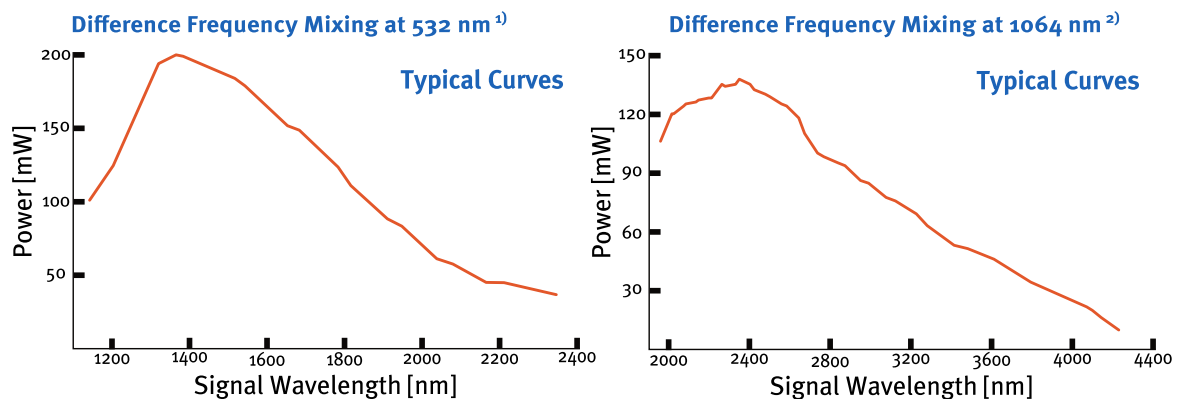

Fiber Laser <sup>3)</sup>	Matisse	Range	Power <sup>1)</sup>
532 nm	690-1015 nm	Difference 1160-2350 nm	> 170 mW at 1350 nm
1064 nm	690-1015 nm	Difference 1940-4260 nm	> 100 mW at 2350 nm

Standard Crystals	Scan Range <sup>4)</sup>
PPCD2-TiS-05	Periodic Poled Crystal, 1.15-1.7 μm 40 GHz
PPCD3-TiS-05	Periodic Poled Crystal, 1.65-2.3 μm 40 GHz
PPCD2-TiS-10	Periodic Poled Crystal, 1.96-2.7 μm 60 GHz
PPCD3-TiS-10	Periodic Poled Crystal, 2.4-4.2 μm 60 GHz

## Periodically Poled Crystal Characteristics

Maximum Length	40 mm
Maximum Width	33 mm
Temperature Range	20-180 °C
Rec. Size of Period Domain	1 mm x 1 mm
Beam Polarization	vertical

## Requirements

Pump Lasers <sup>5)</sup>	Matisse Titanium-Sapphire Laser (max. 5 W output) Single-Frequency Fiber Laser (max. 15 W output)
Ambient Conditions	constant temp. in the 20-30 °C range, 80% max. rel. humidity, non condensing
Cooling	required for crystal (ca. 30 Watt, chiller of pump laser can be used)
Laboratory	vibrational isolated optical table, dust-free air (flow box)
Computer Control	Windows XP / Vista / 7 / 8 / 10, USB-Port

- <sup>1)</sup> Matisse pumped with 15 W, single mode fiber laser 2 W / 532 nm  
<sup>2)</sup> Matisse pumped with 15 W, single mode fiber laser 12 W / 1064 nm  
<sup>3)</sup> for other lasers contact Sirah  
<sup>4)</sup> scan range without change of crystal temperature  
<sup>5)</sup> please contact Sirah for compatibility with other pump lasers

# MixTrain 5/10

## MixTrain with Matisse



## MixTrain

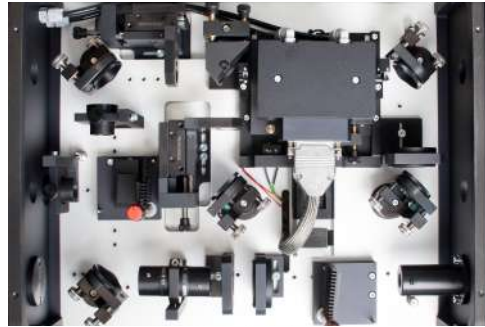

## Oven

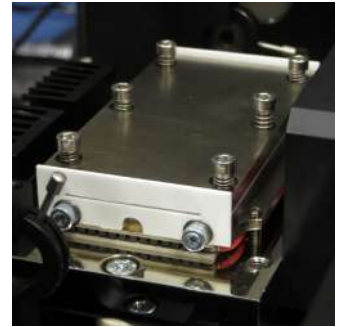

## Optical Layout

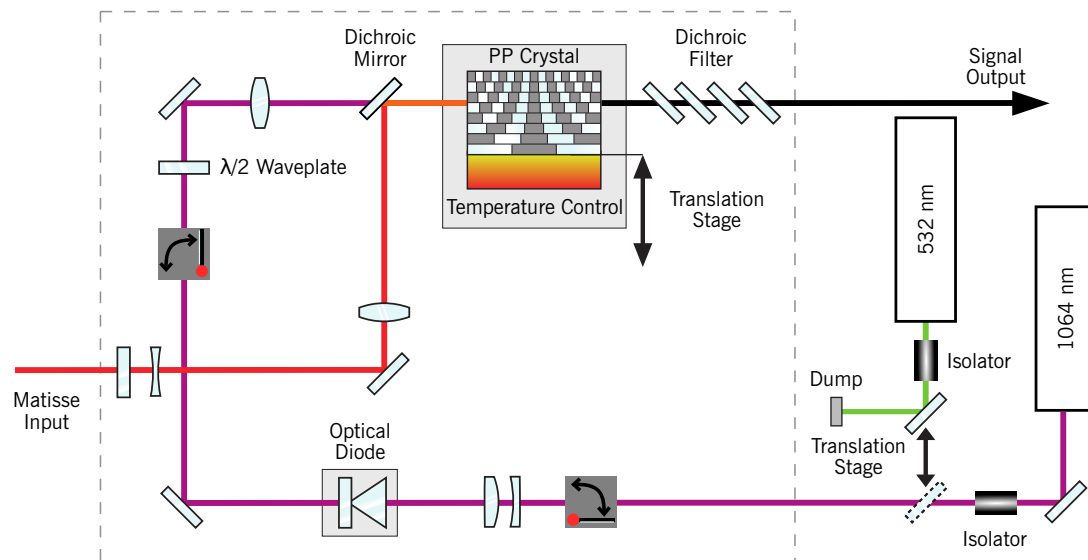

## Dimensions

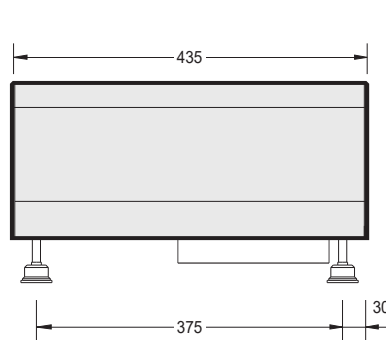

MixTrain (Side View)

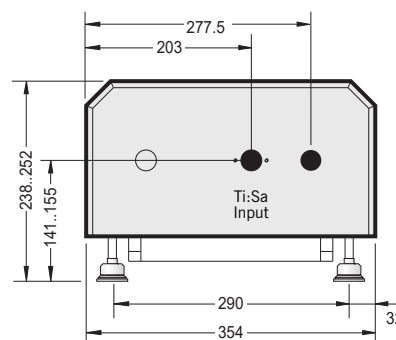

MixTrain (Pump Laser Input End)

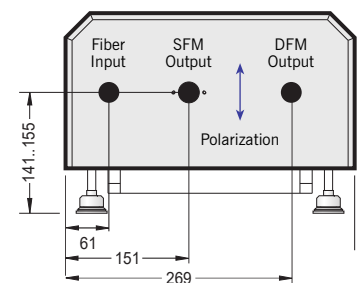

MixTrain (Signal Output End)

All Dimensions in mm  
Specifications are subject to change without notice



Heinrich-Hertz-Straße 11  
D-41516 Grevenbroich  
Sirah Lasertechnik GmbH

Phone +49 (0)2182 829818-0  
Fax +49 (0)2182 829818-40  
Web www.sirah.com

**Sirah**  
Lasertechnik