

MixTrain 19

Frequency Mixing in Periodically Poled Crystals

The MixTrain is using quasi-phase matching in periodically poled crystals for sum- or difference frequency mixing of two cw-lasers. Typically, one of the lasers will be a tunable Titanium-Sapphire laser like the Matisse while the other laser is a powerful fixed wavelength fiber laser operating at 1950 nm.

The system uses a motor controlled translation stage for changing the period of the crystal and a temperature stabilized oven capable of heating up to 180 °C. All optics for beam shaping, polarization control, beam combination, and beam separation are included. An optical diode isolates the fiber laser input from back reflections from the setup.

Tuning Range

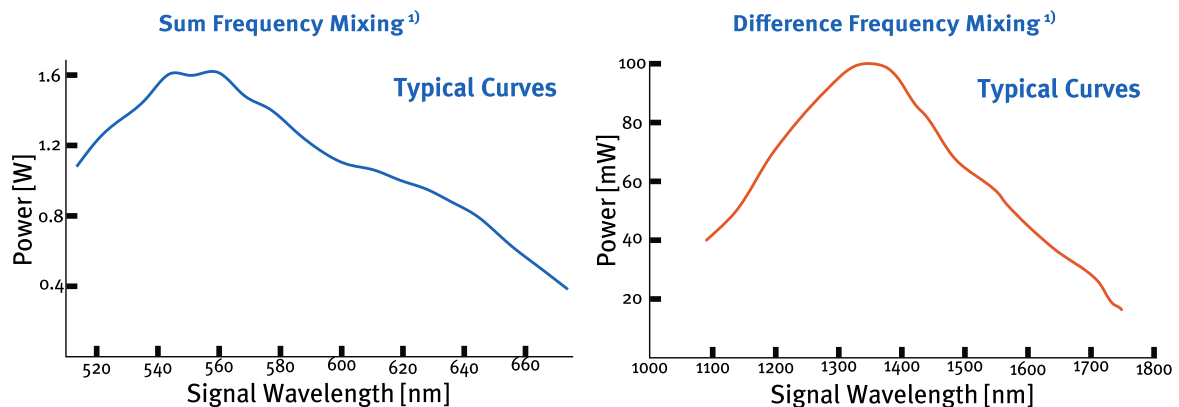

Fiber Laser ²⁾	Matisse	Range	Power ¹⁾
1950 nm	690-1015 nm	Sum 515-664 nm	> 1.5 W at 555 nm
		Difference 1090-1750 nm	> 100 mW at 1350 nm

Standard Crystals	Scan Range ³⁾
PPCS1-TiS-19	Periodic Poled Crystal, 515-585 nm 25 GHz
PPCS2-TiS-19	Periodic Poled Crystal, 575-670 nm 25 GHz
PPCD1-TiS-19	Periodic Poled Crystal, 1045-1380 nm 40 GHz
PPCD2-TiS-19	Periodic Poled Crystal, 1360-1750 nm 40 GHz

Periodically Poled Crystal Characteristics

Maximum Length	40 mm
Maximum Width	33 mm
Temperature Range	20-180 °C
Rec. Size of Period Domain	1 mm x 1 mm
Beam Polarisation	vertical

Requirements

Pump Lasers ⁴⁾	Matisse Titanium-Sapphire Laser (max. 5 W output) Single-Frequency Fiber Laser (max. 15 W output)
Ambient Conditions	constant temp. in the 20-30 °C range, 80% max. rel. humidity, non condensing
Cooling	required for crystal (ca. 30 Watt, chiller of pump laser can be used)
Laboratory	vibrational isolated optical table, dust-free air (flow box)
Computer Control	Windows XP / Vista / 7 / 8 / 10, USB-Port

¹⁾ Matisse 6 W output, fiber laser 5 W output

²⁾ for other lasers contact Sirah

³⁾ scan range without change of crystal temperature

⁴⁾ please contact Sirah for compatibility with other pump lasers

MixTrain with Matisse



MixTrain

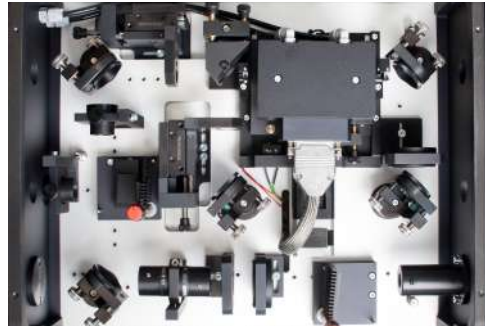

Oven

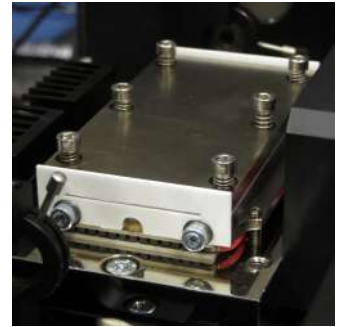

Optical Layout

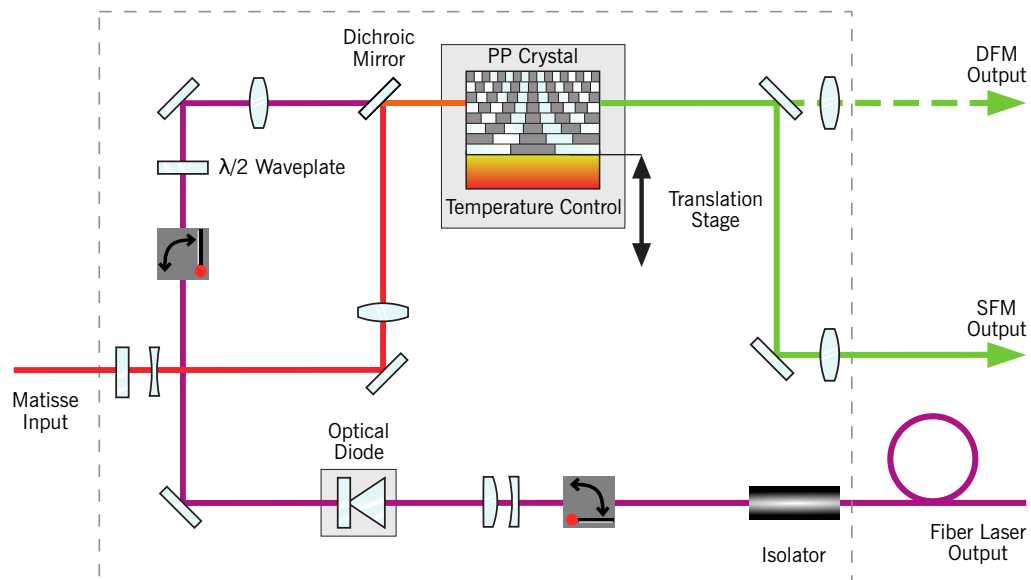

Dimensions

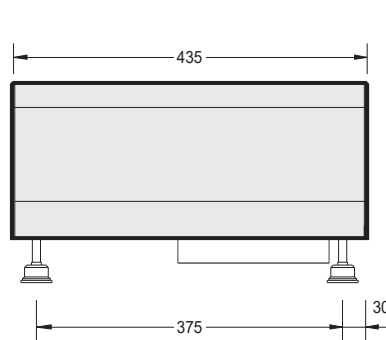

MixTrain (Side View)

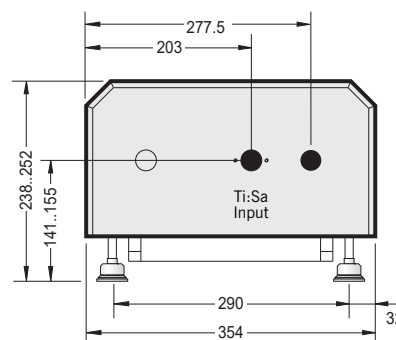

MixTrain (Pump Laser Input End)

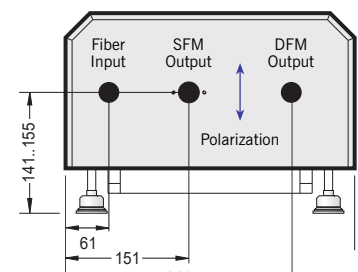

MixTrain (Signal Output End)

All Dimensions in mm
Specifications are subject to change without notice



Heinrich-Hertz-Straße 11
D-41516 Grevenbroich
Sirah Lasertechnik GmbH

Phone +49 (0)2182 829818-0
Fax +49 (0)2182 829818-40
Web www.sirah.com

Sirah
Lasertechnik