

Matisse 2 DR

Passively Stabilized Dye Ring Laser

- High power output up to 7.0 W
- Hands free operation with ELSA (Electronic Laser Self Alignment)
- Low Amplitude Noise: Quiet Laser Operation
- Intracavity EOM available
- Extended scans over nanometers (requires wavemeter, optional fiber launch integrated in Matisse)
- Field serviceable: optics change, maintenance, upgrades, conversion to Matisse 2 TR (Ti:Sa)
- Special optics for enlarged tuning range (420-760 nm)
- Extension modules available from 210-4200 nm

Tuning Range

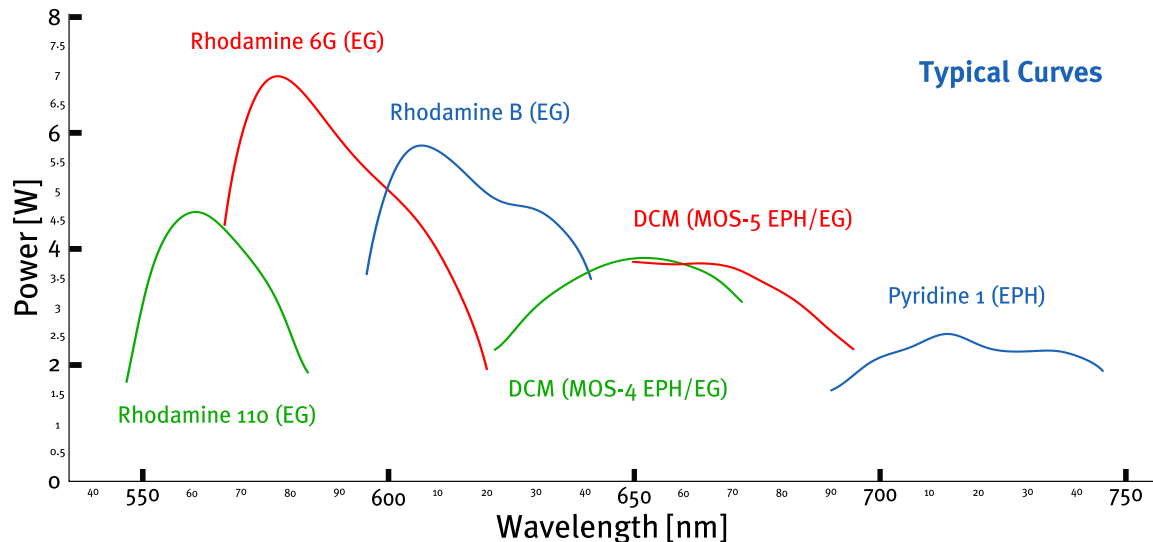

	Millennia eV 25W	Millennia eV 20W	Millennia eV 15W	Millennia eV 10W	Millennia eV 5W
Specified Power ¹⁾	6.0 W	4.5 W	3.0 W	1.8 W	0.8 W
	MOS-4		MOS-5		
Two Optic Sets ^{2) 3)}	550-660 nm		650-760 nm		

General Characteristics

Beam Radius ⁴⁾	0.6-0.7 mm (typical)
Beam Divergence	< 1.2 mrad (half angle)
Linewidth	< 20 MHz rms / 100 msec, < 2 MHz rms / 100 µsec
Amplitude Noise	< 0.5 % rms (above pump noise, added in quadrature)
Scan Range ¹⁾	> 60 GHz
Beam Polarization	horizontal

Requirements

Pump Laser ⁵⁾	Millennia Series
Ambient Conditions	constant temperature in the 20-30 °C range, 80% max. rel. humidity, non condensing
Cooling	required for circulator (~ 300 Watt)
Laboratory	vibrational isolated optical table, dust-free air (flow box)
Computer Control	Windows XP / Vista / 7 / 8 / 10, USB-Port

¹⁾ at maximum of Rhodamine 6G

²⁾ non-standard tuning ranges upon request

³⁾ depending on pump power

⁴⁾ at Matisse output port

⁵⁾ please contact Sirah for compatibility with other pump lasers

Matisse 2 DR

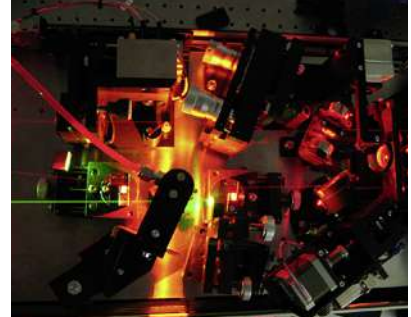
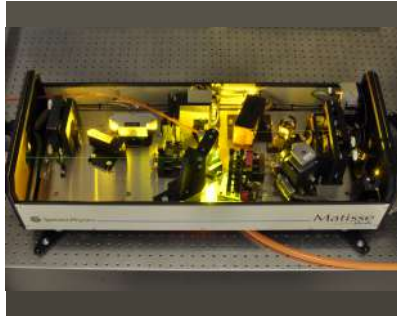

Optical Layout

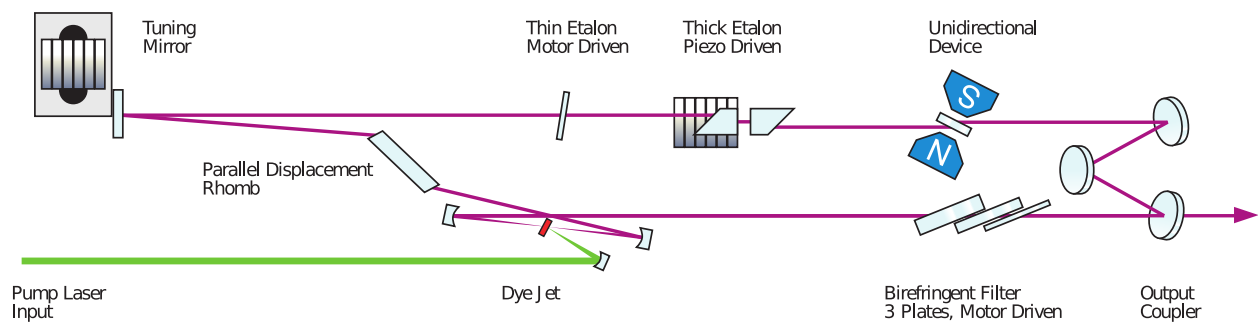

Dimensions

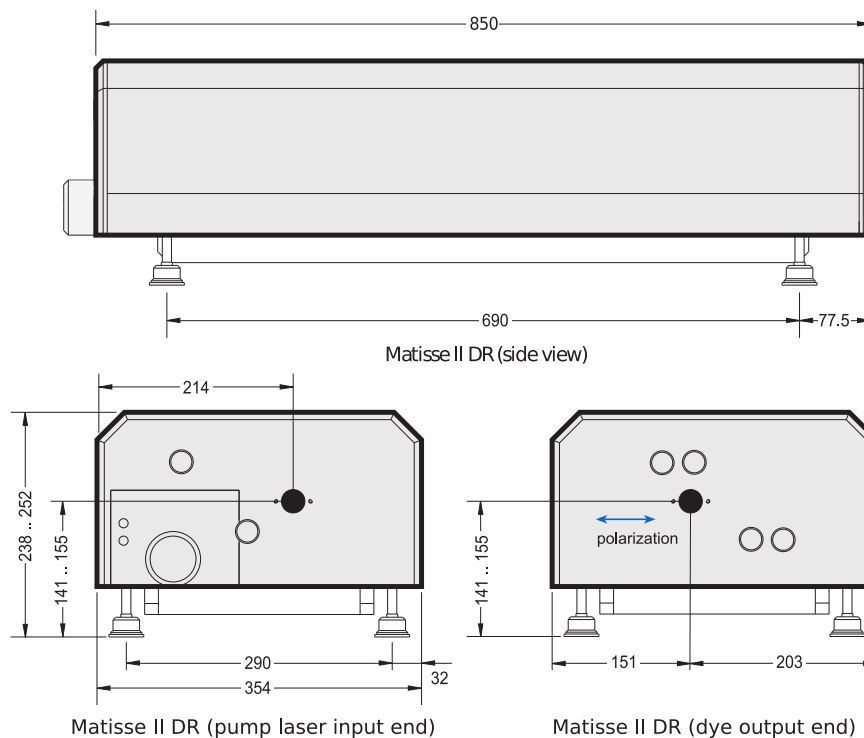

All Dimensions in mm
 Specifications are subject to change without notice
 U.S. Patent 7,489,715



Sirah Lasertechnik GmbH
 Heinrich-Hertz-Straße 11
 41516 Grevenbroich

Phone +49 (0)2182 829818-0
 Fax +49 (0)2182 829818-40
 Web www.sirah.com

Sirah
 Lasertechnik